

FIRE-TEST : DOOR-CONSTRUCTION

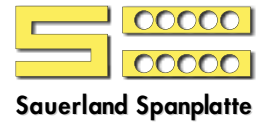

Number : Date :

Customer :

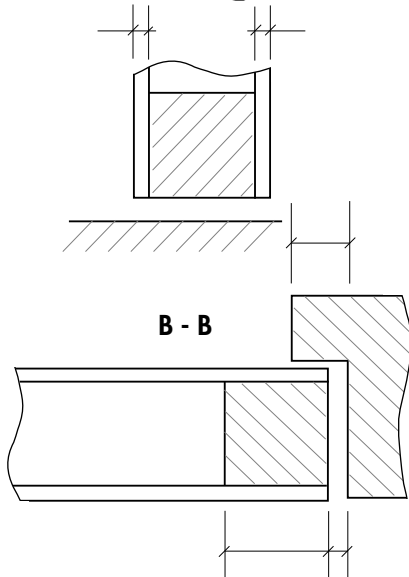
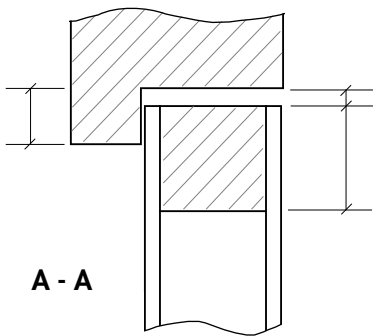
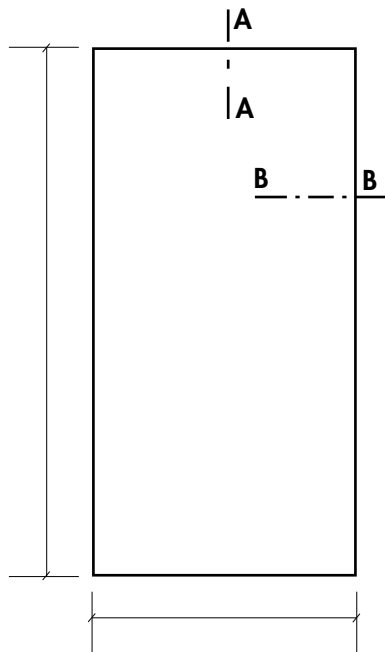

Size

Opening direct. inside / outside (underline correct)

Edge blunt

Core Type _____ Humidity _____
 Sizes _____

Frame _____

Skin _____

Surface _____

Stiles _____

Lipping _____

Internal Stiles. _____

Top rail _____

Bottom rail _____

Intumescent Type _____
 Sizes _____

Sealing _____

Test-conditions: pressure and teperature according to DIN 4102

Result: min

max.deformation (mm : min) top edge _____ E _____
 H _____ bo. edge _____

Reason for end: _____

Remarks: _____

