

# FIRE-TEST : DOOR CONSTRUCTION

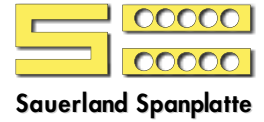

Number :  Date :

Customer :

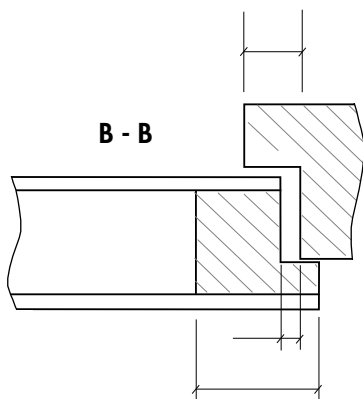
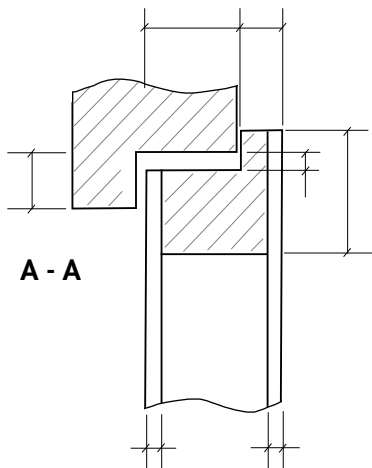
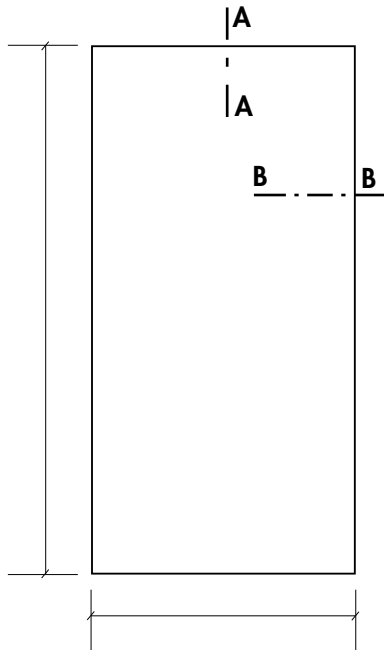

Size

Opening direct. inside/outside (underline correct)  
Edge rebated

Core Type  \_\_\_\_\_ Feuchte \_\_\_\_\_  
Sizes \_\_\_\_\_

Frame  \_\_\_\_\_

Skin  \_\_\_\_\_

Surface \_\_\_\_\_

Stile  \_\_\_\_\_

Lipping \_\_\_\_\_

Internal stiles. \_\_\_\_\_

Top rail \_\_\_\_\_

Botto, rail \_\_\_\_\_

Intumescent Type  \_\_\_\_\_  
Sizes \_\_\_\_\_

Sealing \_\_\_\_\_

**Test-conditions:** pressure and teperature according to DIN 4102

**Result:**  min

max.deformation (mm : min) top edge \_\_\_\_\_ E \_\_\_\_\_  
H \_\_\_\_\_ bottom edge \_\_\_\_\_

Reason for end: \_\_\_\_\_

Remarks: \_\_\_\_\_  
\_\_\_\_\_  
\_\_\_\_\_